

Quick-Rain

Irrigation Controller
6 stations

ENGLISH

TABLE OF CONTENTS

Features	1
Installation Instructions	2
Setting Current Date and Time	4
Setting Start Times	5
Setting Run Times	6
Setting Watering Schedule	6
Running Program Automatically	8
System Off	8
Running Stations Manually	9
Specifications	10

Irrigation controller

6 estaciones Manual de instalación y programación

- Dial control for easy programming.
- Two programs (A/B) with three start times each, independent programming handles many different watering requirements 1 minute to 4 hour run times per station Programmable pump start/master valve by station
- High temperature & Large LCD display for simplified programming, easy to read for schedule review and entry
- Choice of independent day scheduling options, days of the week, odd/even days or day interval for maximum flexibility
- Rain sensor with on/off capabilities
- Memory backup for programming
- Resumable fuse for surge protection
- Vertically aligned mounting holes for ease of installation
- Quick reference instruction card

Before installing and programming, we recommend you read these instructions carefully for proper operation.

NOTE: For your programming ease, dial position can be found to the right of section header and default LCD display to the left of page.

INSTALLATION INSTRUCTIONS

1. Select an INDOOR location near a standard 120/240Vac electric outlet.

Important:

- DO NOT plug in transformer until you have made all wiring connections.
- DO NOT install outdoors or where unit will be exposed directly to adverse weather and/or direct sunlight.
- DO NOT install in area where temperatures are less than 0° C (32° F) or higher than 50° C (122° F).
- DO NOT install on same outlet, or line, as other high current draw products.

2. a) Screw one #10 screw in the wall at the height you'd like to view the LCD. Leave a slight gap between head of screw and wall.
b) Place the keyhole on the back of the controller over the screw and slide unit downward to seat on screw.
c) Remove access door from bottom-front of unit and secure through center screw hole with screw.

3. Wire valves using 18AWG color-coded, multi-strand direct burial wire. **DO NOT** exceed 250 meters wire runs.

- Use one wire per station plus one 'common wire'.
- All valve wires **MUST** be connected before AC power is supplied.

NOTE: Connections that will be buried underground should have watertight connections and be approved for underground use.

- The common wire should connect all valves and become a single wire that connects to the terminal marked 'COM'.

4. If using a pump start relay, or master valve, connect wire to terminal marked 'MV'.

WARNING: Do not connect pump directly to controller. A pump-start relay must be used.

NOTE: Check local regulations to ensure compliance with any wiring, electrical or installation codes.

5. <OPTIONAL> If connecting a rain sensor, remove jumper wire, and install a normally closed sensor to terminals marked 'RAIN'.

CAUTION: Jumper wire must be in place if no sensor is used for proper operation

6. Connect transformer wires to terminals marked 'AC'. - Plug transformer into electrical socket - LCD will light

CAUTION: DO NOT plug in transformer until ALL wiring is checked and complete.

7. Install two AA alkaline batteries (not included). Do not use NiCad or rechargeable batteries.

NOTE: Batteries maintain real time and date in the event of a power failure. The unit can be programmed under battery power only, however, for operation of the valves, AC power must be applied.

Replace batteries once per year. When replacing batteries, do not unplug transformer, or your program will be lost.

DEFAULT MODE: If the batteries fail during a power failure, or there are no batteries in the unit, the unit will reset to factory defaults (See last page for details). After the power resumes, unit will run factory default program until reprogrammed (As long as dial remains in 'Run' position)

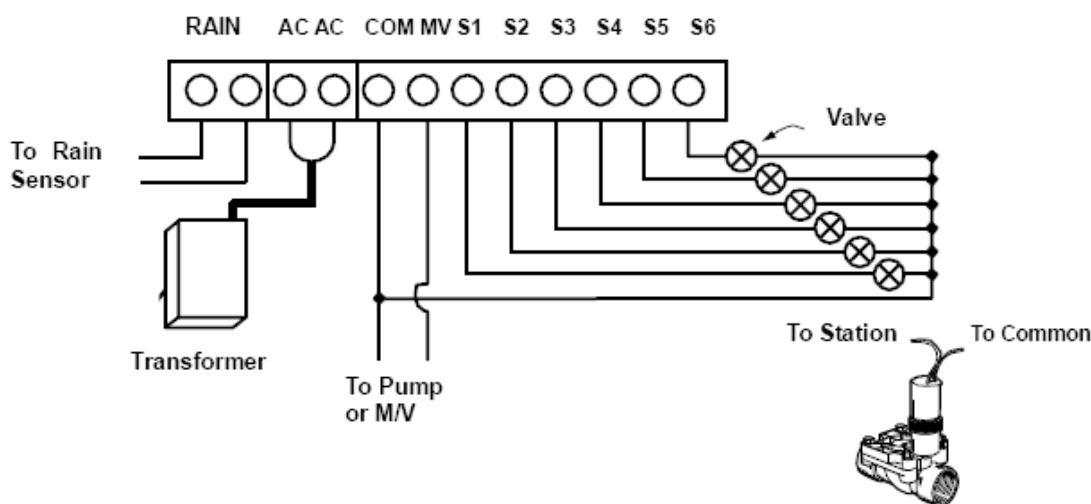

SETTING CURRENT DATE AND TIME

1.

Set 12 or 24 hour mode

 1. Turn the dial to the TIME/DATE position.
 2. Press **【+】** or **【-】** to advance between modes.
 3. Press NEXT.
2.

Set hour

 1. Press **【+】** or **【-】** to advance hour.
 2. Press NEXT.

(Set AM / PM indicator if in 12-hour mode, Press NEXT)
3.

Set minutes

 1. Press **【+】** or **【-】** to advance minutes.
 2. Press NEXT.
4.

Set month

 1. Press **【+】** or **【-】** to advance month
 2. Press NEXT.
5.

Set day

 1. Press **【+】** or **【-】** to advance day
 2. Press NEXT.
6.

Set Year

 1. Press **【+】** or **【-】** to advance year(2000-2099).
 2. Press NEXT.

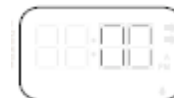
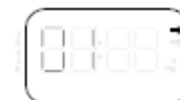

SETTING START TIMES

Setting Program A Start time



1 Set Start Time 1

1. Turn the dial to the START TIMES A position.
2. Press **【+】** or **【-】** to set time (The start times advance in 15 minute increments).
3. Press NEXT for Start Time 2

2 Set Start Time 2

1. Repeat step 1 if Start Time 2 needed.
2. Press NEXT for Start Time 3.

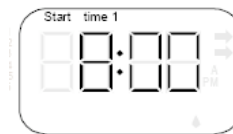

Setting Program B Start time

1. Turn the dial to the START TIMES B position.
 2. The following settings, please repeat what is stated in Setting program A start time.
- Note: One start time will activate all stations sequentially in that program. This eliminates the need to enter each station's start time. Multiple start times in a program can be used for separate morning, afternoon, or evening watering cycles.

Eliminating a Program Start time

To eliminate a start time, turn the dial to the START TIMES A or B position, press **【+】** or **【-】** to set time until you reached 12:00AM(Midnight). From here press the **【-】** , once to reach the OFF position.

Note: If all 3 programmed start times are turned “OFF”, then the program is off. Because there are no start times, there will be no watering with the program. This is a convenient way to stop watering on one program only without turning the dial to the OFF position.

SETTING RUN TIMES (per station)

Setting Program A Run times

1 Set Run Time 1

1. Turn the dial to the Run Time A position. 3
2. Press **【+】** or **【-】** to increase or decrease run time in one minute increments.
3. Press NEXT to program the next station.

2 Set Run Time 2 thru 4 (or 6)

Repeat Step 1 for each successive station.

Setting Program B Run times

1. Turn the dial to the Run Time B position.
 2. The following settings, please repeat what is stated in Setting program A Run times.
- Note: you can set station run times anywhere from 0 to 4 hours.

SETTING WATERING SCHEDULE

Setting Program A Watering Schedule

1 Setting Daily schedule

Allows selection of individual days to water (i.e. Mon, Tue, Fri)

1. Turn the dial to the SCHEDULE A position.
2. With the cursor on a specific day, press the **【+】** to activate a particular day of the week to water. Press the **【-】** to cancel watering for that day. Press NEXT to advance to the next day.
3. Repeat step 2 until all desired days have been selected. The selected days will show with a ▼ to indicate their status ON.

-Last chosen schedule is selected

Press NEXT for Odd or Even day schedule.

2 Setting Odd or Even day schedule

Allows watering on days of month that are odd or even numbers (i.e. - Odd will water on 1st, 3rd, 5th, etc.)

1. With the cursor on Odd/Even, press the **【+】** to select Odd day (▼ stays lit) ; Press the **【-】** to deselect Odd day (blinks over EVEN)
- Last chosen schedule is selected
2. Press the **【+】** to select Even day (▼ stays lit);
Press the **【-】** to deselect Even day (blinks over ODD)
- Last chosen schedule is selected Press NEXT for Interval day schedule.

3 Setting Interval day schedule

Allows selection of interval watering from 0 to 99 days.

1. Press **【+】** or **【-】** to increase or decrease the number of days between watering days(0 to 99).
- Last chosen schedule is selected.
Press NEXT for Daily schedule.

Example: you program the controller at 8:00AM for the following:

Program A Start time 9:00AM Interval = 3 days The unit will run on today at 9:00AM and water program A. Then, the unit will wait 3 days and water again at 9:00AM and so on. Had you programmed the controller at 10:30AM rather than at 8:00AM, the unit would have watered tomorrow at 9:00AM and then watered every 3 days after that at 9:00AM.

Note: Only one of these schedule options is available simultaneously for each independent program. Each independent program can utilize different/same schedule option.

Setting Program B Watering Schedule

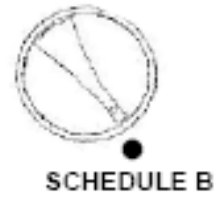

1. Turn the dial to the SCHEDULE B position.
2. The following settings, please repeat what is stated in **Setting program A Watering Schedule**.

RUNNING PROGRAM AUTOMATICALLY



1 After completing any programming, turn the dial to the RUN position to enable automatic execution of all selected programs and start times. Watering will not occur unless dial is in the RUN position.

Note: When the controller is in watering time, the LCD will display the watering station and the remaining time; when the unit is No Water Day, it will display the current time.

When one stations completing watering, another station will start watering automatically but there is a short delay and the LCD will display 0:00.

SYSTEM OFF

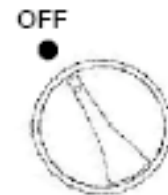

Valves currently watering will be shut off after the dial is turned to the OFF position for three seconds. All active programs are discontinued and watering is stopped. To return controller to normal automatic operation, simply return dial to RUN position.

RE-SETTING or ERASING CONTROLLER MEMORY

Manual runs stations of Program A only.

If you want to eliminate all past data input to controller, as if to start over as new, with no data in controller, proceed as follows:

When the dial is in OFF position, press the **【+】** and **【-】** simultaneously for 3 seconds. "CLR" will be displayed and flashed four times on LCD and all the entered data will be erased, including the start times, run times and watering schedule.

RUNNING STATIONS MANUALLY

1 Set station to manual

1. Turn the dial to MANUAL position.
2. Press NEXT until desired station is displayed.
3. Press **【+】** or **【-】** to increase or decrease run time for the station.
4. Press NEXT to program the next station.
5. Repeat steps 2 and 3 for each station if desired.
6. Press NEXT until you reach the station that you would like watering to begin.

2 Place dial in RUN position

1. Set station will run immediately(program will water the entire program beginning with the station number last left in the display, then controller will return to automatic mode with no change in the previously set program).
- To end running manual, turn dial to 'OFF' position

Note: The station that is on the display when you turn the dial to RUN will be the first station to water. The controller will then proceed to water in sequential order only. It will not water previous stations. Example: If you turn the dial to RUN with the display reading station 3, the controller will water stations 3 through 6 in the program, but not return to stations 1 and 2.

Bypass Rain Sensor

A rain sensor or any other type of normally closed micro-switch sensor may be used in conjunction with this controller. Sensor will interrupt controller output. Note: Under RUN mode, if the sensor has detected the adequate rainfall, "RAIN" will be displayed on the LCD.

DEFAULTS

12 Hour Clock

TIME 00:00 AM

DATE 01/01/2000DAY

PROGRAM A: Weekday watering schedule with all days active.

One start time at 00:00AM

All stations are set to zero run time.

PROGRAM B: No watering days, station run time or start times.

SENSOR Normally closed

RESET To reset unit to factory defaults, unplug transformer and remove batteries, wait for LCD to turn off, then plug transformer back in and re-install batteries.

SPECIFICATIONS

Transformer Input: 120VAC, 60HZ or 230VAC, 50/60HZ

Transformer Output: 24VAC, 0.6A (max. total)

Station Output: 24VAC, 0.28A (max. per station)

Master Valve/Pump Start Relay Output: 24VAC, 0.28A (maximum)

Sensor Input: Normally-closed rain switch

Battery: Two AA alkaline batteries required

Temperature Limit Specification:

Operating - 32°F to 122°F(0 to 50)°C°C

Storage - 14°F to 185°F(-10 to 85)°C°C

Relative humidity: ≤95%

Dimension (L x W x H): 5.51" x 3.94" x 1.48" (140*100*37.5mm)



VYR S.A

Polígono Industrial N-1
09001 Burgos (SPAIN)

Tlf: (+34) 947-262226
Fax: (+34) 947-262226
Mail: vyrsa@vyrsa.com

www.vyrsa.com